

Unirain F2614 - F2614W

Full Circle Impact Sprinkler Low and Medium flow Plastic



Application

Suitable for low and medium flow irrigation under trees.

Its lower jet radius doesn't directly reach foliage, avoiding fruit deterioration. Indicated also for nurseries and greenhouses.

Sturdy in design, it features significant improvements, notably its durability and its protected bearing sleeve thread, eliminating the possibility of breakage after impact.

Highly recommended for banana plantations for its angle of incidence, anti-UV treatment for exposed parts, protection of delicate parts and accessories, in particular the feed-tube. available in three formats and suitable for rapid installation anywhere.

Advantages

- Sturdy design. Protective cap against impact and dirt.
- Due to an innovative system, the crown that holds the arm spring allows tension variation to adjust the sprinkler performance to extreme pressure or flow conditions.
- Compression spring protector guided by the bearing to ensure correct sliding between the protector and the sprinkler body.
- Thanks to their bayonet coupling system, the nozzles are easy to change and clean.
- Three different types of water guide vane can be used to achieve the desired coverage and spray balance according to the available pressure.

Technical specifications

- Full circle impact sprinkler
- 1/2" male thread.
- 14° Nozzle trajectory angle
- Pressure range: 1,03-4,14 Bar
- Nozzle range: 5/64" (1,98mm) - 9/64" (3,57mm)
- High-resistance thermoplastics protected against UV radiation, and stainless steel.
- Color-coded anti abrasive acetal resin nozzles carved in millimetres and inches for a better identification.
- F2614W (low pressure model)



Typical curves of range and distribution of water depending on the model of vane used



Units Conversion	
FLOW	PRESSURE
m ³ / h (metro cúbico por hora)	mca (metro de columna de agua)
l / h (litro por hora)	PSI (Pounds per Square Inch)
GPM (Gallons per Minute)	kg / cm ² (Kilogramo por centimetro cuadrado)
CFM (Cubic Feet per Minute)	
1 CFM = 1.699 m³ / h	1 PSI = 0.70307 mca
1 GPM = 227.1192 l / h	1 kg / cm² = 14,22 PSI

F2614	PRESSURE (Bar)	NOZZLE 7/64"					NOZZLE 1/8"					NOZZLE 9/64"				
		Throw radius depending on vane (m)					Throw radius depending on vane (m)					Throw radius depending on vane (m)				
		L/H	30V	sin	30RV	30BV	L/H	30V	sin	30RV	30BV	L/H	30V	sin	30RV	30BV
ONE NOZZLE AND VANE TO HIGH RANGE	1.03	307	8.7	8.0	7.7	7.3	398	8.9	8.0	7.8	7.2	498	10.6	9.5	9.2	8.3
	1.38	354	9.6	8.6	8.4	7.8	460	9.9	8.6	8.5	7.8	576	11.6	10.1	9.9	8.7
	1.72	397	10.3	9.2	9.0	8.3	515	10.7	9.2	9.0	8.1	644	12.4	10.5	10.4	9.1
	2.07	435	10.9	9.6	9.5	8.7	565	11.3	9.7	9.5	8.6	706	13.0	10.9	10.7	9.4
	2.41	471	11.3	10.0	9.9	9.0	610	11.8	10.0	9.9	8.9	763	13.4	11.2	11.0	9.6
	2.76	504	11.8	10.4	10.3	9.4	653	12.3	10.5	10.3	9.2	816	12.9	10.7	10.6	9.1
	3.10	534	12.1	10.6	10.5	9.6	693	12.7	10.7	10.5	9.4	866	13.2	10.9	10.7	9.2
	3.45	564	12.3	10.7	10.6	9.7	731	12.9	10.9	10.7	9.5	913	13.5	11.1	10.8	9.3
	3.79	591	12.5	11.0	10.9	9.9	767	13.2	11.0	11.0	9.7	958				
	4.14	618	12.8	11.2	11.1	10.1	801	13.5	11.4	11.2	9.9	1001				

F2614W	PRESSURE (Bar)	NOZZLE 5/64"					NOZZLE 3/32"				
		Throw radius depending on vane (m)					Throw radius depending on vane (m)				
		L/H	30V	sin	30RV	30BV	L/H	30V	sin	30RV	30BV
ONE NOZZLE AND VANE TO HIGH RANGE	1.03	153					227	8.6	8.0	7.6	7.3
	1.38	177	9.2	8.5	8.3	8.0	262	9.4	8.6	8.3	8.0
	1.72	199	9.8	9.0	8.8	8.5	293	10.1	9.2	8.9	8.6
	2.07	218	10.3	9.5	9.3	8.8	321	10.7	9.6	9.4	8.9
	2.41	237	10.7	9.8	9.6	9.2	347	11.1	9.9	9.8	9.2
	2.76	253	11.0	10.1	9.9	9.5	371	11.5	10.3	10.2	9.5
	3.10	269	11.4	10.4	10.2	9.7	394	11.7	10.5	10.4	9.8
	3.45	284					415	12.0	10.8	10.7	9.9
	3.79	298					435	12.2	10.9	10.9	10.1
	4.14	312					455				

Shaded areas not recommended to obtain a correct distribution.

Throw distance obtained with sprinkler on a 0.9 m lift.

Tested under ideal conditions. Results can be affected by wind, bad hydraulic conditions or any other adverse factors.

Every model of Unirain sprinkler allows using three different kinds of vanes to achieve the desired throw radius and pulverisation balance depending on the available system pressure. This system, exclusively provided by Unirain, allows obtaining high uniformity.

- Vane 30V (white) It increases the sprinkler coverage radius to its maximum. To obtain a good grade of pulverisation, the system pressure must be high (from 2.76 Bar).
- Without vane Using the nozzle without any vane, the throw radius will be slightly reduced compared to the previous option, but it will improve the water distribution. Recommended for medium system pressures (2.07 Bar).
- Vane 30RV (Red) Its inner structure creates a slight rotation inside the nozzle, obtaining a good pulverisation grade, but reducing the throw distance. To be used under low pressure conditions (2.07 Bar).
- Vane 30BV (Blue) This combination will achieve the highest pulverisation grade, but will also provide the minimum coverage radius. It's used under extreme low pressures (1.38 Bar).

WARRANTY AND EXCLUSIONS

The manufacturer guarantees its products for direct customer against any defects in materials or manufacture for a period of two years from the original date of purchase, only when the products have been used under normal operating conditions. The manufacturer assumes no responsibility for installation, removal or repairs carried out by unauthorised personnel. The manufacturer's liability under this warranty is limited to the replacement or repair of defective parts and the manufacturer does not accept responsibility for damages to crops or any other consequential damages deriving from defects in the products covered by this warranty.

THE PRESENT WARRANTY SUPERCEDES AND VOIDS ALL OTHER WARRANTIES, WHETHER EXPRESS OR IMPLIED, INCLUDING THOSE OF MERCHANTABILITY AND FITNESS FOR PARTICULAR PURPOSES OR ANY OTHER ATTRIBUTING LIABILITY TO THE MANUFACTURER.

No agent, employee or representative of the manufacturer is authorised to void, alter or add to the conditions contained in this warranty, nor to take responsibility for, nor to make guarantees not specified herein.

COMPONENT NUMBER	CODE	DESCRIPTION	MATERIAL	QUANTITY
1	03020	Sprinkler Body F2614	POM + UV	1
2	03022	Sprinkler Arm F2614	POM + UV	1
3	03027	Arm Pin F2614	POM + UV	1
4	03005	Arm Cap F2614	POM + UV	1
5	03019	Castellated Turnbuckle	POM	1
6	03007	Spring Arm F2614	Stainless Steel	1
7	03011	Bearing Spring F2614	Stainless Steel	1
8	03012	Bearing Body F2614	POM + UV	1
9	03016	Bearing Nut F2614	POM + UV	1
10	03010	Bearing Body Lock	High Density PE	1
11	03018	1/2" PTFE Bearing Washer	PTFE	1
12	03014	1/2" PE Bearing Washer	High Density PE	1
13	03013	1/2" Red PU Bearing Washer	PU	1

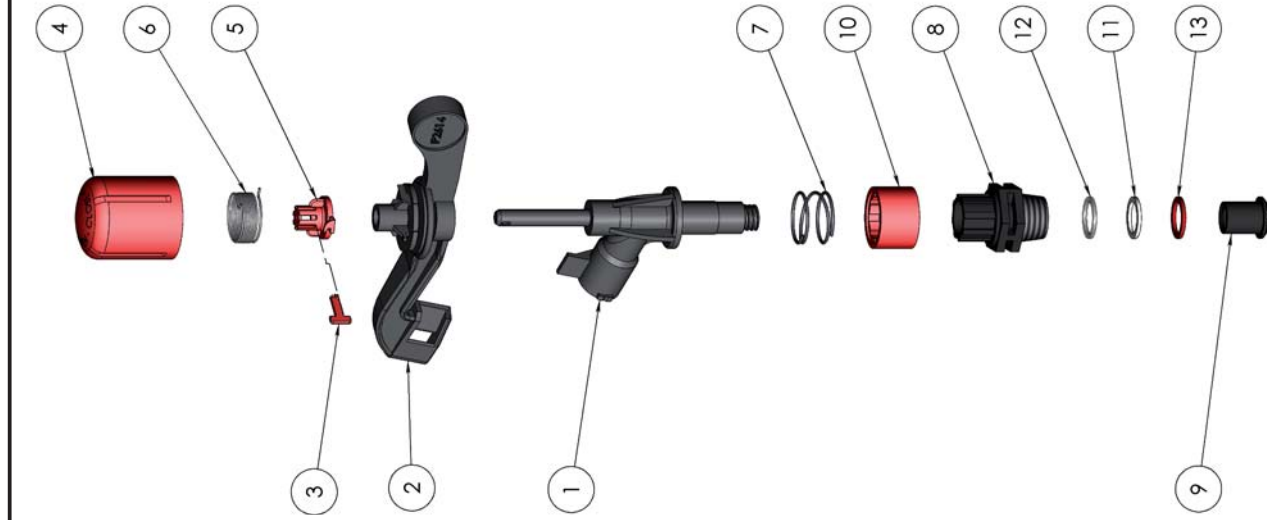

Process/Manufacturer UNIRAIN	Size A3	Material	Code 03904UNI
	Scale 26/06/09 E.G.B.	Name F2614 Sprinkler	
<small>PRIVATE AND CONFIDENTIAL THE INFORMATION CONTAINED ON THIS PLAN IS FOR UNIRAIN USE ONLY. FORBIDDEN CHANGE OR AMENDMENT OF VALUES OF THE PLAN WITHOUT A CONSENT IN WRITING.</small>			

COMPONENT NUMBER	CODE	DESCRIPTION	MATERIAL	QUANTITY
1	03021	Sprinkler Arm F2614W	POM + UV	1
2	03020	Sprinkler Body F2614	POM + UV	1
3	03005	Arm Cap F2614	POM + UV	1
4	03007	Spring Arm F2614	Stainless Steel	1
5	03010	1/2" Series Bearing Body Lock	High Density PE	1
6	03011	Bearing Spring F2614	Stainless Steel	1
7	03012	Bearing Body F2614	POM + UV	1
8	03013	1/2" Red PU Bearing Washer	PU	1
9	03014	1/2" PE Bearing Washer	High Density PE	1
10	03015	1/2" NBR Bearing Washer	NBR	1
11	03016	Bearing Nut F2614	POM	1
12	03019	Castellated Turnbuckle	POM + UV	1
13	03024	triangle F2614W	POM + UV	1
14	03025	triangular clamp	POM + UV	1
15	03027	Arm Pin F2614	POM + UV	1

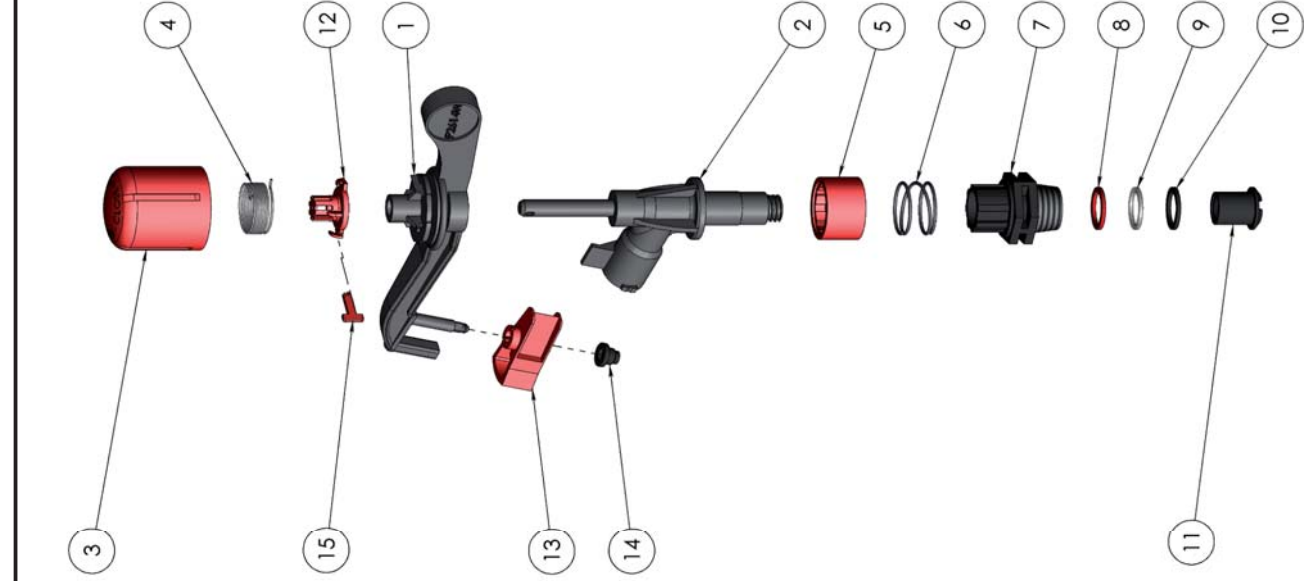

Process/Manufacturer UNIRAIN	Size A3	Material	Code 03903
	Scale 26/06/09 E.G.B.	Name F2614W Sprinkler	
<small>PRIVATE AND CONFIDENTIAL THE INFORMATION CONTAINED ON THIS PLAN IS FOR UNIRAIN USE ONLY. FORBIDDEN CHANGE OR AMENDMENT OF VALUES OF THE PLAN WITHOUT A CONSENT IN WRITING.</small>			