

# Unirain F26 - F26W

## Full Circle Impact Sprinkler Low and Medium flow Plastic



### Application

Full circle impact sprinkler. Output water jet : 23°. Very suitable for low (F26W) and medium flow (F26), for low growing corps, minimize evaporation losses and wind effect. The F26 model is also recommended for frost-proof irrigation thanks to its configuration and quality of materials. The F26W model is not recommended for frost-proof irrigation.

Sturdy in design, it features significant improvements, notably its durability and its protected bearing sleeve thread, eliminating the possibility of breakage after impact.

Its bearing sleeve thread is protected against breakage after impacts.

The protection of springs reduces the negative effects of ice.

### Advantages

- Sturdy design. Protection cap for shock, dirt and ice.
- Due to an innovative system, the crown that holds the arm spring allows tension variation to adjust the sprinkler to extreme pressure or flow conditions.
- Bearing spring protector guided by the bearing to grant a correct sliding of the sprinkler body on the protector itself.
- Thanks to their bayonet coupling system, it is easy to change and clean the 3Q nozzles.
- Three different vanes can be used to achieve the desired coverage and pulverisation balance according to the available system pressure.

### Technical specifications

- Full circle impact sprinkler.
- Frost protection irrigation (F26W not recommended).
- 1/2" Male base threaded.
- 23° Nozzle trajectory angle.
- Pressure range: 1.03 - 4.14 Bar.
- Nozzle range: 5/64" (2,98mm)-9/64" (3,57mm).
- High-resistance thermoplastics protected against UV radiation, and stainless steel.
- Color-coded anti abrasive acetal resin nozzles carved in millimetres and inches for a better identification.
- F26W (low pressure model)



### Typical curves of range and distribution of water depending of the model of vane used



Units Conversion	
FLOW	PRESSURE
m <sup>3</sup> / h (metro cúbico por hora)	mca (metro de columna de agua)
l / h (litro por hora)	PSI (Pounds per Square Inch)
GPM (Gallons per Minute)	kg / cm <sup>2</sup> (Kilogramo por centimetro cuadrado)
CFM (Cubic Feet per Minute)	
1 CFM = 1.699 m <sup>3</sup> / h	1 PSI = 0.70307 mca
1 GPM = 227.1192 l / h	1 kg / cm <sup>2</sup> = 14,22 PSI

F26	PRESSURE (Bar)	NOZZLE 7/64"					NOZZLE 1/8"					NOZZLE 9/64"				
		Throw radius depending on vane (m)					Throw radius depending on vane (m)					Throw radius depending on vane (m)				
		L/H	30V	sin	30RV	30BV	L/H	30V	sin	30RV	30BV	L/H	30V	sin	30RV	30BV
ONE NOZZLE AND VANE TO HIGH RANGE	1.03	307	10.3	9.4	9.1	8.6	398	10.5	9.4	9.2	8.5	498	10.6	9.5	9.2	8.3
	1.38	354	11.2	10.0	9.8	9.1	460	11.5	10.0	9.8	9.0	576	11.6	10.1	9.9	8.7
	1.72	397	11.8	10.5	10.3	9.5	515	12.2	10.5	10.3	9.3	644	12.4	10.5	10.4	9.1
	2.07	435	12.2	10.8	10.7	9.8	565	12.7	10.9	10.7	9.6	706	13.0	10.9	10.7	9.4
	2.41	471	12.5	11.1	10.9	10.0	610	13.0	11.1	10.9	9.8	763	13.4	11.2	11.0	9.6
	2.76	504	12.8	11.3	11.2	10.2	653	13.4	11.4	11.2	10.0	816	13.8	11.5	11.3	9.8
	3.10	534	13.0	11.4	11.3	10.3	693	13.6	11.5	11.3	10.1	866	14.1	11.7	11.4	9.9
	3.45	564	13.2	11.5	11.4	10.4	731	13.8	11.7	11.5	10.2	913	14.4	11.9	11.6	10.0
	3.79	591	13.3	11.7	11.6	10.5	767	14.0	11.8	11.6	10.3	958				
	4.14	618	13.5	11.8	11.7	10.6	801	14.2	12.0	11.8	10.4	1001				

F26W	PRESSURE (Bar)	NOZZLE 5/64"					NOZZLE 3/32"				
		Throw radius depending on vane (m)					Throw radius depending on vane (m)				
		L/H	30V	sin	30RV	30BV	L/H	30V	sin	30RV	30BV
ONE NOZZLE AND VANE TO HIGH RANGE	1.03	153					227	10.1	9.4	9.0	8.6
	1.38	177	10.8	10.0	9.7	9.4	262	11.0	10.0	9.7	9.3
	1.72	199	11.3	10.4	10.1	9.8	293	11.6	10.5	10.2	9.8
	2.07	218	11.7	10.7	10.5	10.0	321	12.0	10.8	10.6	10.0
	2.41	237	11.9	10.9	10.7	10.2	347	12.3	11.0	10.9	10.2
	2.76	253	12.1	11.1	10.9	10.4	371	12.5	11.2	11.1	10.4
	3.10	269	12.3	11.2	11.0	10.5	394	12.6	11.3	11.2	10.5
	3.45	284					415	12.7	11.4	11.3	10.6
	3.79	298					435	12.8	11.5	11.5	10.7
	4.14	312					455				

Shaded areas not recommended to obtain a right distribution.

Throw distance obtained with sprinkler on a 0.9m lift.

Tested under ideal conditions. Results can be affected by wind, bad hydraulic conditions or any other adverse factors.

Three different kinds of vanes can be used to achieve the desired throw radius and pulverisation balance depending on the available system pressure. This Unirain exclusive system provides high uniformity.

- Vane 30V (white) It increases the sprinkler coverage radius to its maximum. To obtain a good grade of pulverisation, the system pressure must be high (from 4.14 Bar).
- Without vane Using the nozzle without any vane, the throw radius will be slightly reduced compared to the previous option, but it will improve the water distribution. Recommended for medium system pressures (2.76 Bar).
- Vane 30RV (Red) Its inner structure creates a slight rotation inside the nozzle, obtaining a good pulverisation grade, but reducing the throw distance. To be used under low pressure conditions (2.07 Bar).
- Vane 30BV (Blue) This combination will achieve the highest pulverisation grade, but will also provide the minimum coverage radius. It's used under extreme low pressures (1.38 Bar).

### WARRANTY AND EXCLUSIONS

The manufacturer guarantees its products for direct customer against any defects in materials or manufacture for a period of two years from the original date of purchase, only when the products have been used under normal operating conditions. The manufacturer assumes no responsibility for installation, removal or repairs carried out by unauthorised personnel. The manufacturer's liability under this warranty is limited to the replacement or repair of defective parts and the manufacturer does not accept responsibility for damages to crops or any other consequential damages deriving from defects in the products covered by this warranty.

**THE PRESENT WARRANTY SUPERCEDES AND VOIDS ALL OTHER WARRANTIES, WHETHER EXPRESS OR IMPLIED, INCLUDING THOSE OF MERCHANTABILITY AND FITNESS FOR PARTICULAR PURPOSES OR ANY OTHER ATTRIBUTING LIABILITY TO THE MANUFACTURER.**

No agent, employee or representative of the manufacturer is authorised to void, alter or add to the conditions contained in this warranty, nor to take responsibility for, nor to make guarantees not specified herein.

COMPONENT NUMBER	CODE	DESCRIPTION	MATERIAL	QUANTITY
1	03001	Sprinkler Body F26	POM	1
2	03003	Sprinkler Arm F26	POM	1
3	03007	Spring Arm F26	Stainless Steel	1
4	03019	Castellated turnbuckle F26	POM	1
5	03027	Arm Pin F26	POM	1
6	03005	Arm Cap F26	POM	1
7	03011	1/2" Series Bearing Spring	Stainless Steel	1
8	03010	1/2" Series Bearing Body Lock	High Density PE	1
9	03012	Bearing Body F26	POM	1
10	03014	1/2" PE Bearing Washer	High Density PE	1
11	03013	1/2" Red PU Bearing Washer	Anti Hydrolysis PU	1
12	03016	Bearing Nut F26	POM	1
13	03018	1/2" PTFE Bearing Washer	PTFE	1

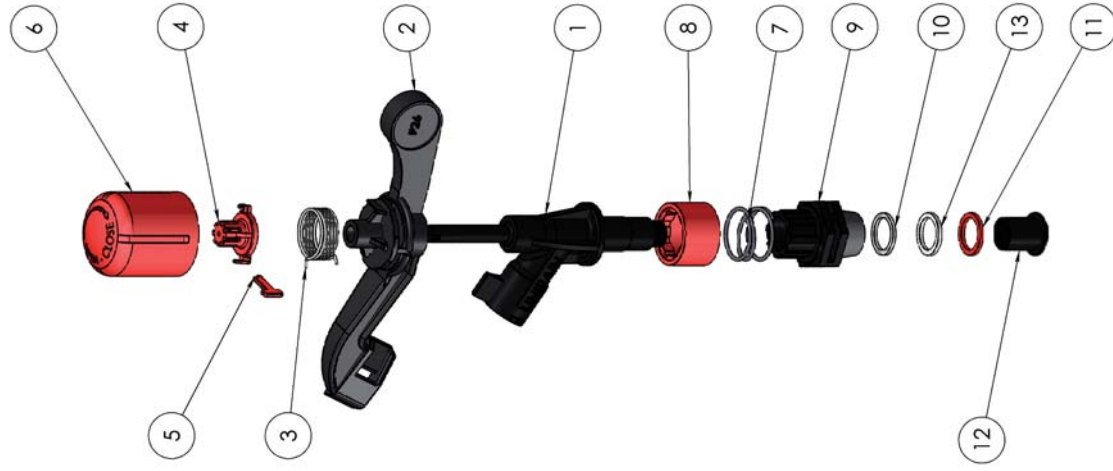

Process/Manufacturer		Size	Material	Code
UNIRAIN		A3		03901
		Scale	Name	
		14/04/09	F26 Sprinkler	
		J.N.E.	 <b>unirain</b> <small>IREGISTRATION PRODUCTS</small>	
<small>PRIVATE AND CONFIDENTIAL          THE INFORMATION CONTAINED ON THIS PLAN          IS FOR UNIRAIN USE ONLY.          FORBIDDEN CHANGE OR AMENDMENT          OF VALUES OF THE PLAN          WITHOUT A CONSENT IN WRITING.</small>				

COMPONENT NUMBER	CODE	DESCRIPTION	MATERIAL	QUANTITY
1	03002	Sprinkler Arm F26W	POM	1
2	03001	Sprinkler BodyF26	POM	1
3	03005	Arm Cap F26	POM	1
4	03007	Spring Arm F26	Stainless Steel	1
5	03010	1/2" Series Bearing Body Lock	High Density PE	1
6	03011	1/2" Series Bearing Spring	Stainless Steel	1
7	03012	Bearing Body F26	POM	1
8	03016	F26 Bearing Nut F26	POM	1
9	03019	Castellated turnbuckle F26	POM	1
10	03024	Arm Triangle F26W	POM	1
11	03025	F26W Triangle clamp	POM	1
12	03027	Arm Pin F26	POM	1
13	03013	1/2" Red PU Bearing Washer	Anti Hydrolysis PU	1
14	03014	1/2" PE Bearing Washer	High Density PE	1
15	03015	1/2" NBR Bearing Washer	NBR	1



Process/Manufacturer		Size	Material	Code
UNIRAIN		A3		03900
		Scale	Name	
		25/06/09	F26W Sprinkler	
		M.R.M.	 <b>unirain</b> <small>IREGISTRATION PRODUCTS</small>	
<small>PRIVATE AND CONFIDENTIAL          THE INFORMATION CONTAINED ON THIS PLAN          IS FOR UNIRAIN USE ONLY.          FORBIDDEN CHANGE OR AMENDMENT          OF VALUES OF THE PLAN          WITHOUT A CONSENT IN WRITING.</small>				